

Home > General Industry > Locking systems > Latches and locks > M20 quarter-turn fasteners > [M20 193M Quarter Turn Latches](#)

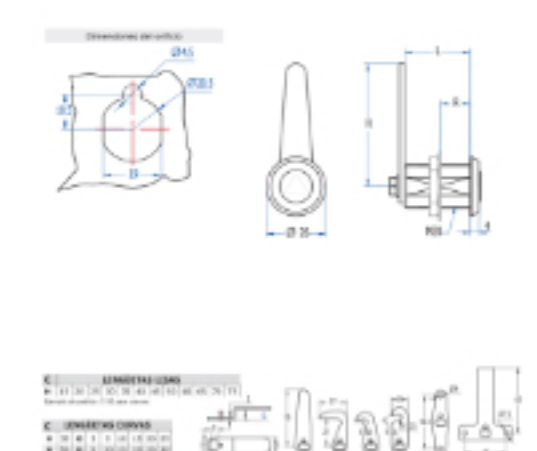

## M20 193M Quarter Turn Latches

### LOCKING SYSTEM

Quarter turn latches for door with thickness up to 6mm. Constant cam pressure against cabinet frame avoids unnecessary openings caused by vibrations. For general applications where no common keys were necessary.



KEY FORM	Triangular 8 mm
MATERIAL	Zamak
FINISH	Chromium plated
FEATURES	L=29 mm / Rmax = 23 mm
WEIGHT(grams)	73
Locking direction	90° Right
ACCESORIES	M20 Nuts, M20 metallic washer, Lock washer
KEY	3018T

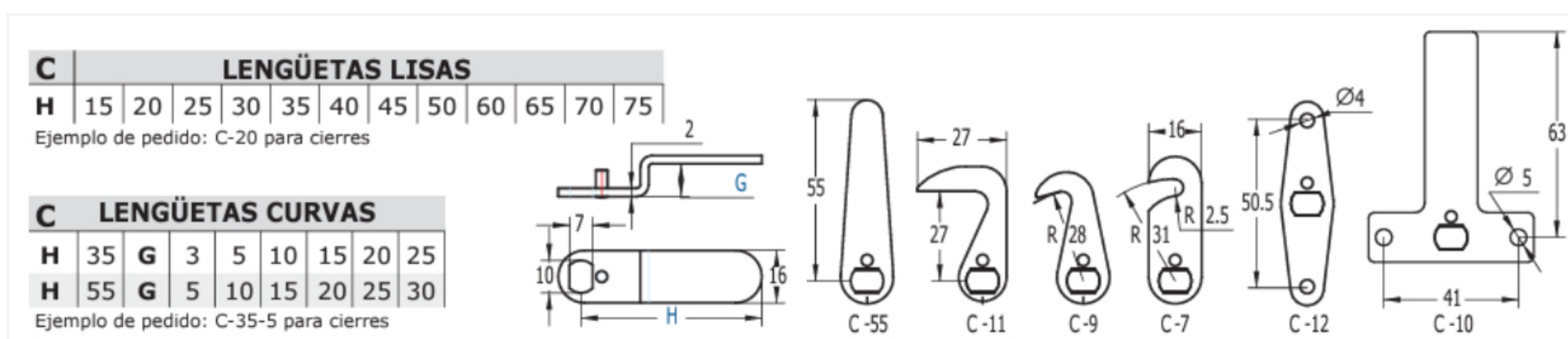
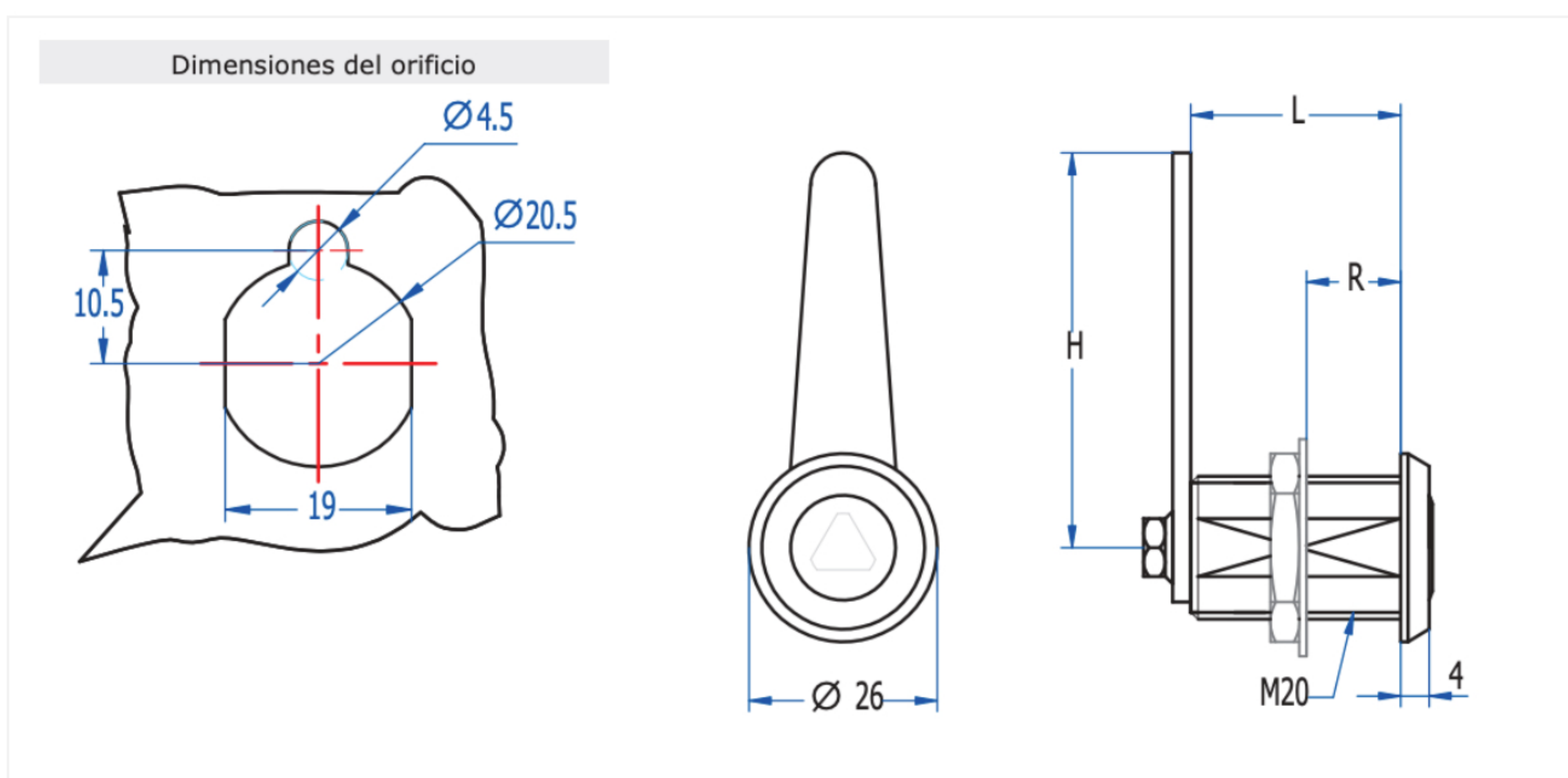

Categories: [General Industry](#), [Latches and locks](#), [Locking systems](#), [M20 quarter-turn fasteners](#)

